



PROCESS-SYSTEMS

SCREWDRIVER Hand held/Automatic

Reliable – Intelligent – Versatile

SCREWDRIVER

STIWA MECHATRONIC SYSTEMS – YOUR PLUG & WORK PARTNER FOR OPTIMIZED PRODUCTION

As a leading manufacturer of automation technology, we have been providing products, projects and services for many years, thereby enabling optimized technology integrations with the best possible overall effect. Through the targeted interaction of mechanics, software and electronics, we achieve production solutions that guarantee the

greatest possible flexibility, standardization, and safety. Our approach is all about “cooperative growth”, meaning we are there every step of the way along our client’s value added chain. No matter whether you need supply, handling, process, or automation systems, STIWA is your partner for mechatronic special solutions!

PROCESS-SYSTEMS SCREWDRIVER

Servo-electric screwing, turning, and installation processes in industrial manufacturing are among the classic technological components of modern manufacturing and automation systems. STIWA screwdriver solutions are used to process modern assembly units for a wide range of applications, even with low cycle times. Documented and safety-relevant processes, representing the standard in the automotive industry, are among the main applications here.

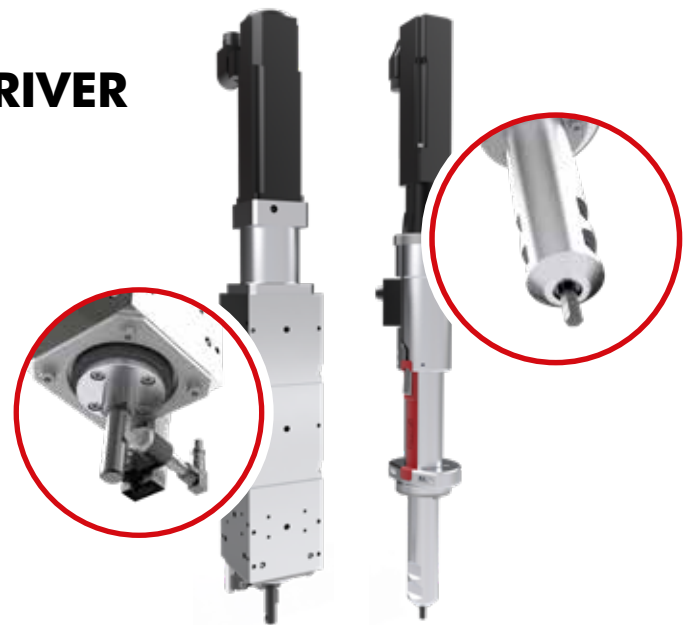

MECHANICAL STRUCTURE

STIWA screwing, turning, and installation systems are integrated into adaptive housings and equipped with powerful highly dynamic servomotors. The

specific drives are fitted with a highly sensitive torque sensor above the transmission. An integrated tool sensor also helps to ensure processes are reliable.

INTELLIGENT MEANS OF PRODUCTION

With high-performance control cycles of our products, we enable you to control your processes almost in real time. Included basic software guarantees networked processes. Easy integration ensures quick implementation and optimized control. There is also the option of an ERP connection for operation and product data collection, which opens up further analysis options and records important parameters from your production processes.

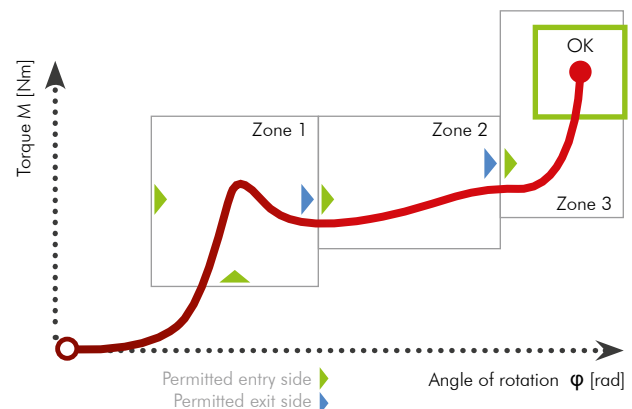



OBJECTIVES AND IMPACT

- » **Quality:** Precise switch-off behavior and high accuracy for the quality requirements in your production.
- » **Flexibility:** Full flexibility in terms of screwing strategies and evaluation methods.
- » **Traceability:** Process results and standard values for each screw position are assigned to a defined product and documented.
- » **Connection:** Communication and interface packages are available for integration into your control environment. Long-term availability of the data is guaranteed through the transfer into a central system.
- » **Analysis:** The operating conditions of the machine as well as the production data of the process are interlinked intelligently, thereby optimizing your production.
- » **Ergonomics:** Low vibration and noise generation.

CHARACTERISTICS

- » **Support for the most common torquing procedures:** torque, differential torque, angle of rotation, angle in relation to the torque threshold, differential torque with seating process
- » **Wide range of evaluation methods:** incline, angle, gradient, speed
- » **Functions & traceability:** Suitable for VDI 2862 (category A)

BENEFITS

Define the optimal process according to your requirements for an efficient implementation with all necessary parameters for OK and NOK parts. This guarantees professional management of the production process within your company, even across multiple sites, whilst keeping the costs of implementation to a minimum.



» We offer individual training courses and workshops for your specific requirements.

OPTIONAL ACCESSORIES

- » **Hand held screwdriver:** Guide stand (optionally with counterweight and cable)
- » **Automatic screwdriver:** Feed axes (100 to 464 mm stroke)
- » **Chuck** (spring loaded)
- » **Bits**
- » **Barcode scanner**
- » **Inline calibration units** (as per DIN 51309)
- » **Analysis software**
- » **Screw feeding** (incl. handling components)

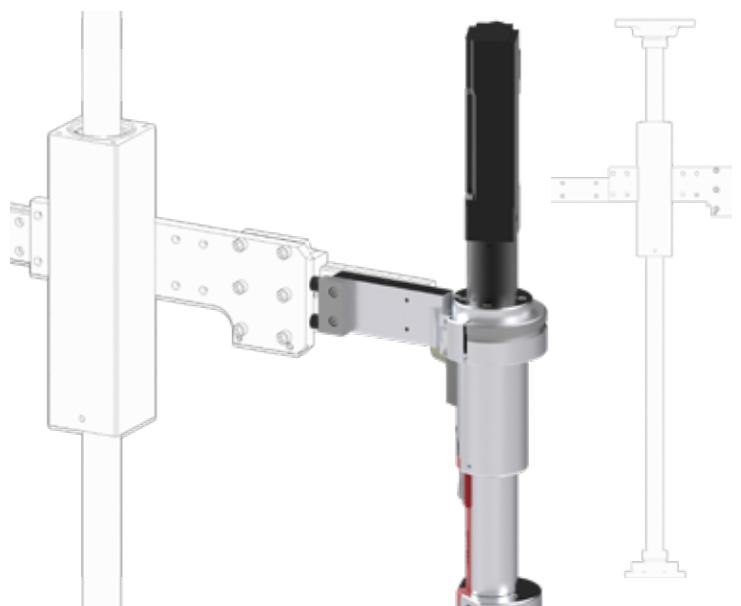



TECHNICAL DATA

Screwdriver	Hand held screwdriver		Automatic screwdriver		
Maximum (intermittent torque)	0 – 15 Nm	0 – 30 Nm	0 – 30 Nm	0 – 100 Nm	0 – 260 Nm
Permanent torque	4,5 Nm	10,1 Nm	6,8 Nm	40,6 Nm	75,2 Nm
Idle speed	888 rpm ⁻¹	572 rpm ⁻¹	1,000 rpm ⁻¹	438 rpm ⁻¹	375 rpm min ⁻¹
Weight	3,6 kg	5,9 kg	7 kg	15 kg	36 kg
Height	609 mm	733,6 mm	628 mm	690,3 mm	884,6 mm
Width	86 mm	86 mm	80 mm	100 mm	140 mm
Depth	178 mm	178 mm	111,5 mm	133,5 mm	155,3 mm
Pinion shaft	6.3 mm (1/4 inch – hexagonal)	6.3 mm (1/4 inch – hexagonal)	Ø 12 mm	Ø 20 mm	Ø 25 mm
Power supply	3 x 400 V AC ± 5% 50/60 Hz				
Max. back-up fuse	13 A				
Switch cabinet (H/W/D)	630/500/380 mm				
Interface	EtherCAT or ProfiNet (S7-1500)				
Ergonomics	Replaceable release button (2 positions) Visual status display via LED				

COMPLETELY INTEGRATED:

- » Flexible plug & work solutions tailored to your needs
- » Control of the IIoT (Industrial Internet of Things): Optimized technology and system integration thanks to many years of experience in the production and networking of automation systems
- » Safe processes with the best possible overall effect and lowest total costs
- » Adaptive, subsequent production: Based on the pre-production processes and according to the situational requirements
- » Comprehensive standardization – high scalability



Your contact person

STIWA Automation GmbH
 Mechatronic Systems
 Markus Hauer
 Salzburger Straße 52
 4800 Attnang-Puchheim, Austria

Tel.: +43 7674 603 - 6012
 Fax: +43 7674 603 - 214
 Cell: +43 664 80 80 3712
 markus.hauer@stiwa.com
 www.stiwa.com